

OLYMPUS[®]

Your Vision, Our Future

I.C.T, S.L.
INSTRUMENTACIÓN CIENTÍFICO TÉCNICA

POLARIZING MICROSCOPE

CX31-P

*Quality, performance and versatility for
multiple applications, from education to research*

UIS
UNIVERSAL
INFINITY SYSTEM



Polarizing microscope CX31-P: superb image clarity and sophisticated functions for high throughput in routine medical and industrial inspections.

The CX31-P is a high-quality polarizing microscope that's ideal for training, with the wide-ranging functions and superior durability required in every field of research.

Its excellent optical performance is matched with the versatility to meet the demands of many different kinds of applications, from double-refraction examination of the structure and characteristics of transparent specimens to complex analyses of rocks, fibers, macromolecules and new materials.

Central control, with compact intermediate attachment U-PA for orthoscopic and conoscopic observation

Every kind of operation is made easier by this microscope's central control, including the detachment/attachment of a Bertrand lens to switch between orthoscopic and conoscopic observations, focusing of conoscopic images, and rotation or detachment/attachment of analyzer and clump at any angle.

Compatibility with several compensators to meet various different needs

The same slot is used for attachment of a tint plate, a 1/4 wavelength plate and compensators for measuring retardation.

Special polarizing objectives with minimal distortion

The CX31-P accommodates high-performance polarizing observation UIS objectives including the PL4xP, ACH-P series and UPLFL-P series. As well as minimizing optical distortion, these objectives feature improved polarizing performance to obtain sharp, high contrast images.

Precision adapter maintaining accurate center of field of view

U-CTAD centering adapters for objectives are provided for precise polarized observations and easy magnification change.

Superior frame rigidity prevents blurred images

Frame rigidity is crucially important, maintained by optimizing the alignment of systems inside the microscope body, including the focusing mechanism and stage supporting system. As well as stable and steady optical performance, the CX31-P features a rotatable stage with vernier for outstanding durability.

New binocular tube (U-BI30P) that prevents crossline slant

A newly developed binocular tube prevents the crossline slant that can be caused by adjusting the interpupillary distance. In addition, the direction of polarizing light oscillation can be precisely aligned.

Cost efficient digital imaging system

For high-performance, cost-efficient digital imaging, just attach an Olympus Camedia digital camera to the eyepiece of the binocular tube. Alternatively, use the DP12 digital camera to the trinocular tube, specifically designed for use with a microscope, and featuring a controller with built-in LCD monitor.

Ideal for medical/biological applications, including gout inspection

Gout inspections can be performed simply and easily by attaching a U-GAN analyzer via the polarizing intermediate attachment U-KPA. This combination is also effective in making inspections for amyloid and urinary resident or observing living cells in muscular tissue.

Easy attachment of mechanical stage

U-FMP mechanical stage can be attached, making it easy to move specimens into the desired position.



Biotite granite (PL4XP)



Tencel (ACH20XP)

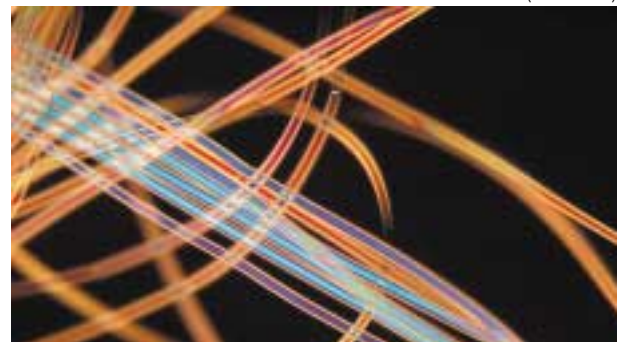

ACH-P series objective + U-CTAD centering adapters



U-FMP mechanical stage



Camedia configuration example



Compensators



Intermediate units



DP12 microscope digital camera



Plates

Plate	Applications
① U-TP530 tint plate	Can effect easily visible color changes even with faintly tinted samples.
② U-TP137 1/4 wavelength retardation plate	Used to change linear polarized light to circular polarized light and vice versa.

Measuring range of compensators

Compensators	Measurement range	Applications
③ U-CWE2 quartz wedge	550-2,200nm (4λ)	Approximate measurement of retardation level (crystal, macromolecules, etc.)
④ U-CSE Senarmont	0-546nm (1λ)	Measurement of retardation level (crystals, living organisms, etc.), Enhancement of image contrast (living organisms, etc.)
⑤ U-CTB Thick Berek	0-11,000nm (20λ)	Measurement of high retardation level (3λ < R* < 20λ), (crystals, macromolecules, fibers, light elasticity strain, etc.) *R=retardation level
⑥ U-CBE Berek	0-1,640nm (3λ)	Measurement of retardation level (R* < 3λ), (crystals, macromolecules, fibers, living organisms, etc.) R=retardation level
⑦ U-CBR1 Brace-Koehler 1/10λ	0-55nm (1/10λ)	Measurement of low retardation level (living organisms, etc.)
⑧ U-CBR2 Brace-Koehler 1/30λ	0-20nm (1/30λ)	Enhancement of image contrast (crystal, macromolecules, etc.)

CX31-P SYSTEM DIAGRAM

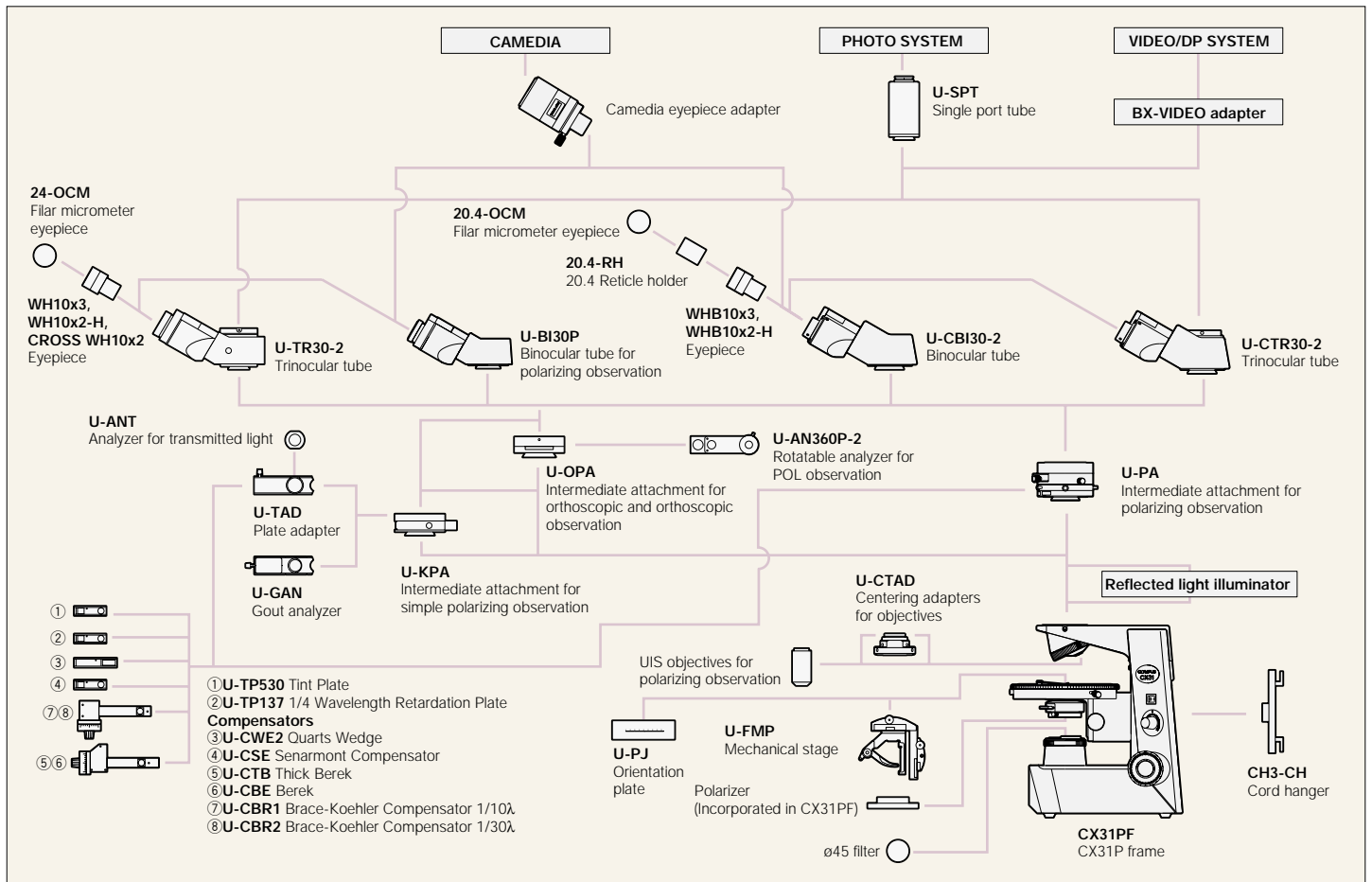

CX31-P specifications

Item	Specifications	
Optics	UIS optical system (infinity-corrected)	
	Objective	Objectives for polarized light observation, ACH-P series, UPFL-P series
	Eyepiece	WHB10x3, WH10x2-H, CROSS WH10x2 Field Number: 22 WHB10x3, WHB10x2-H Field Number: 20
Observation tube	Binocular	U-BI30P Field Number 22
		U-CBI30-2 Field Number: 20
	Trinocular	U-TR30-2 Field Number 22, observation optical path binocular:straight tube = 100:0/20:80/0:100 U-CTR30-2 Field Number: 20, observation optical path fixed binocular:straight tube= 50:50
Conoscopic Intermediate tube (U-PA)	Bertrand lens	Incorporated, detachable, focusable
	Changeover between orthoscopic/conoscopic observation	Engage or disengage of Bertrand lens Position: ● IN Position: ○ OUT
	Analyzer	Incorporated, detachable, 180° rotatable, lockable in any position 2° increments, minimum retardation resolution 6', using vernier scale
	Slot for compensators	Tint plate (U-TP530), 1/4 wavelength retardation plate (U-TP137) and various compensators attachable
Microscope Body	Illuminator	6V30W halogen lamp, pre-centered, pre-focused, with field diaphragm Power source incorporated, 100-120V/220-240V 0.85/0.45A 50/60Hz
	Condenser	Strain-free polarizing condenser N.A. 0.9 (with oil immersion: 1.25), Aperture iris diaphragm incorporated Polarizer 360° rotatable, detachable
	Stage	Polarizing rotatable stage with centering function 360° rotatable, lockable in any position 360° graduated in 1° increments (minimum retardation resolution 6', using vernier scale)
	Revolving Nosepiece	Quadruple, fixed arm, inclined
	Focusing	Rack & pinion Full stroke range: 25mm, Minimum graduation in fine movement: 2.5µm Upper limit stop mechanism in coarse movement Tension adjustment on coarse focus adjustment knob

Objective specifications

Model	Numerical Aperture	Working Distance
PL4xP	0.1	22.0mm
ACH10xP	0.25	6.1mm
ACH20xP	0.40	3.0mm
ACH40xP	0.65	0.45mm
ACH100xOP	1.25	0.13mm

Model	Numerical Aperture	Working Distance
UPLFL4xP	0.13	13.0mm
UPLFL10xP	0.30	3.1mm
UPLFL20xP	0.50	1.6mm
UPLFL40xP	0.75	0.51mm
UPLFL100xOP	1.30	0.10mm

CX31-P dimensions

(Unit: mm)

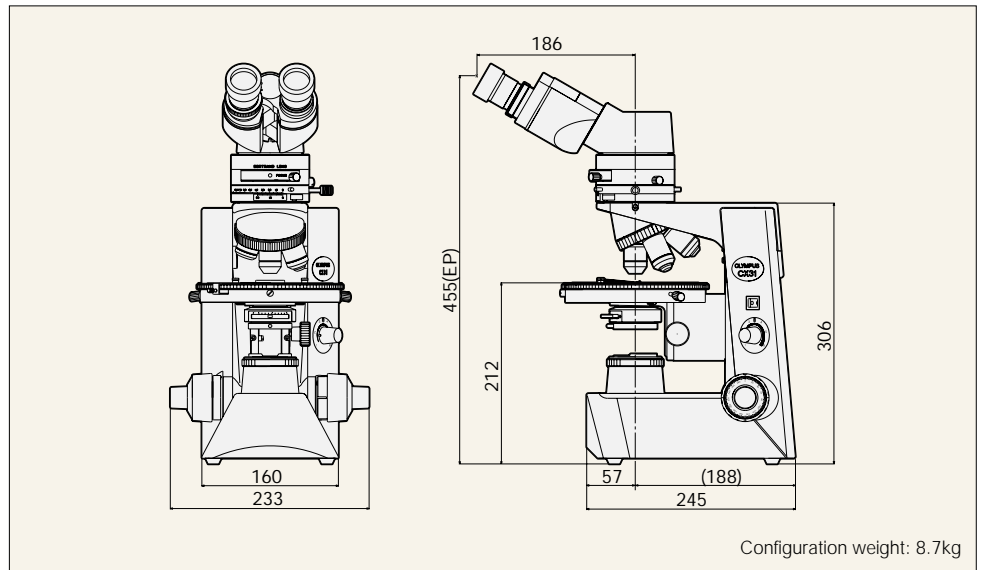

As of Oct. 1, 2003, Olympus Optical Co., Ltd. is named Olympus Corporation.

Specifications are subject to change without any obligation on the part of the manufacturer.



OLYMPUS

OLYMPUS CORPORATION
Shinjuku Monolith, 3-1, Nishi Shinjuku 2-chome, Shinjuku-ku, Tokyo, Japan
OLYMPUS OPTICAL CO. (EUROPA) GMBH.
Postfach 10 49 08, 20034, Hamburg, Germany
OLYMPUS INDUSTRIAL AMERICA, INC.
One Corporate Drive, Orangeburg, NY 10962, U.S.A.
OLYMPUS SINGAPORE PTE LTD.
491B River Valley Road, #12-01/04 Valley Point Office Tower, Singapore 248373

I.C.T. S.L. - INSTRUMENTACION CIENTIFICA TÉCNICA, S.L.
Avda. de Juan Carlos I, 24 · 26140 Lardero (La Rioja) · España
Tel: (+34) 902 193 170 · Fax: (+34) 902 193 167
[Http://www.ictsl.net](http://www.ictsl.net) · E-mail: información@ictsl.net

www.olympus.com